

WSC Series 4-stage Battery Chargers

WSC-1250 / WSC-2425

WSC-1280 / WSC-2440

User's manual

Please read this manual carefully before installing and starting up this device.

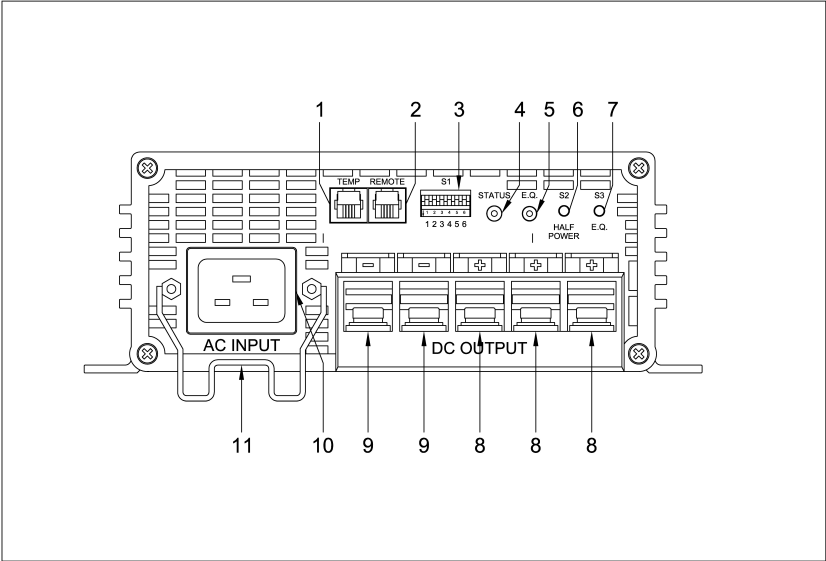

Figure 1 Charger Front View

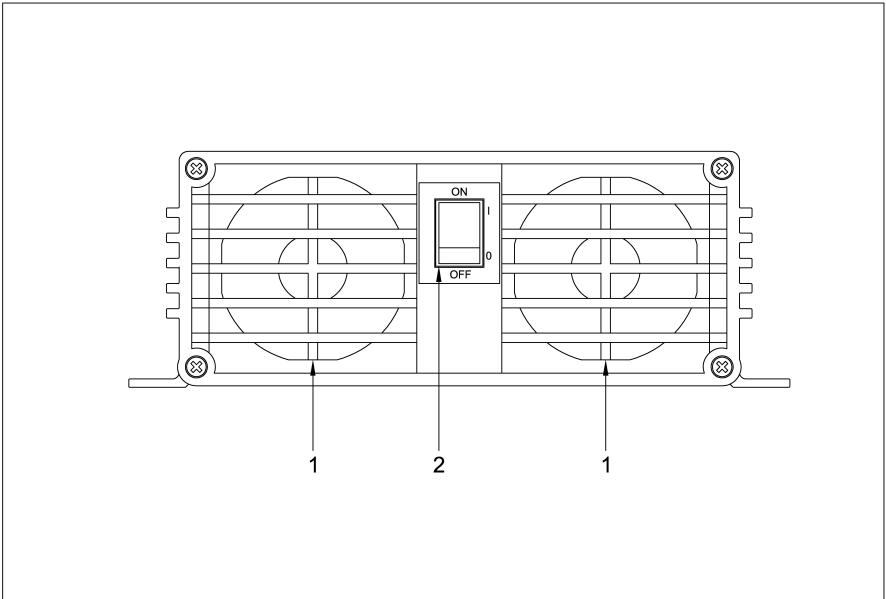

Figure 2 Charger Rear View

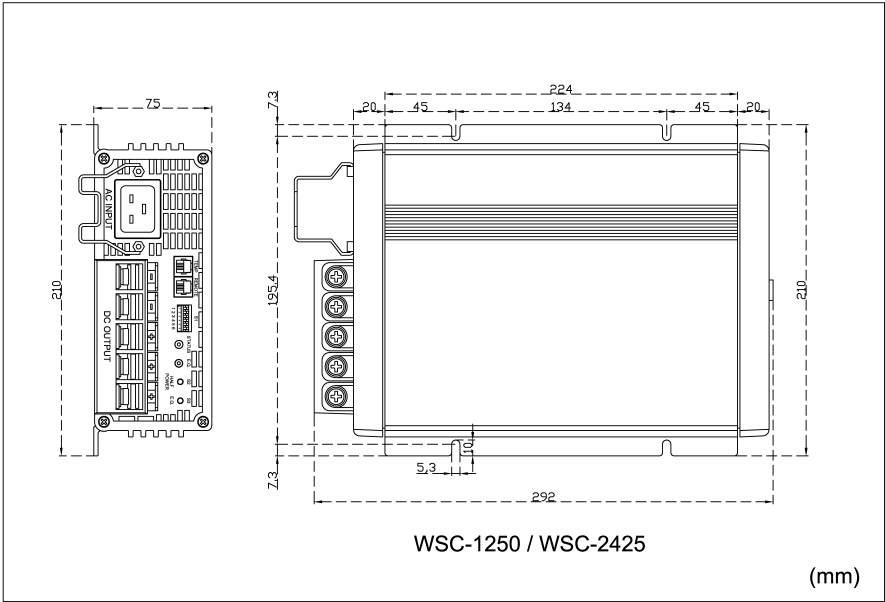

Figure 3 Charger Top View

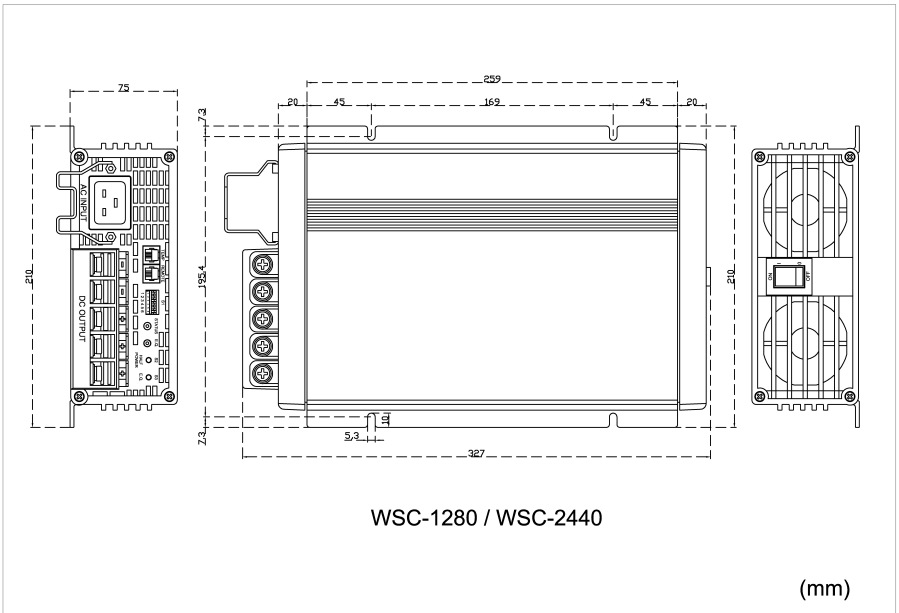

Figure 4 Charger Top View

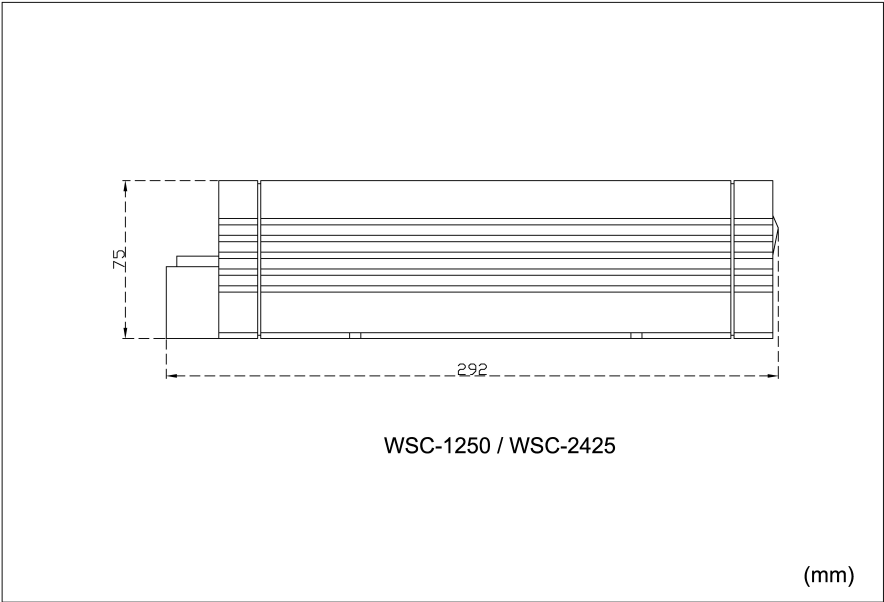

Figure 5 Charger Side View

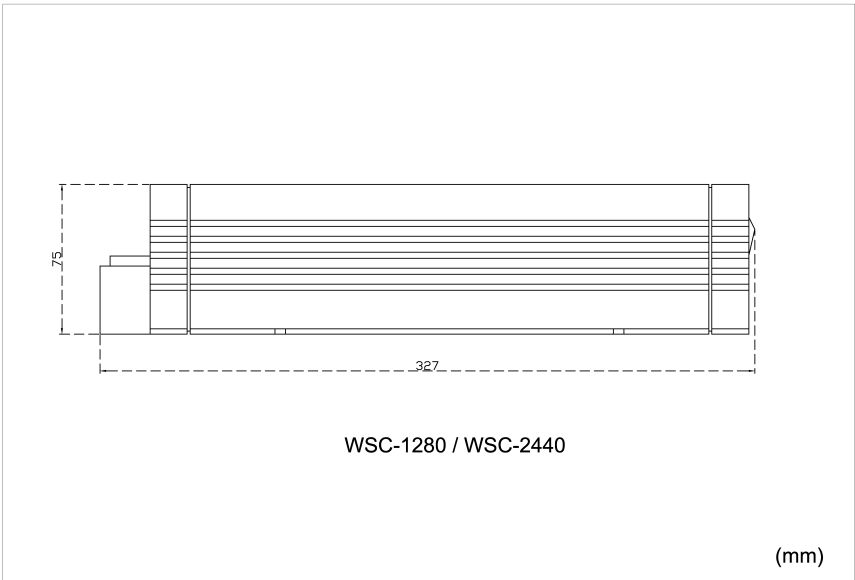

Figure 6 Charger Side View

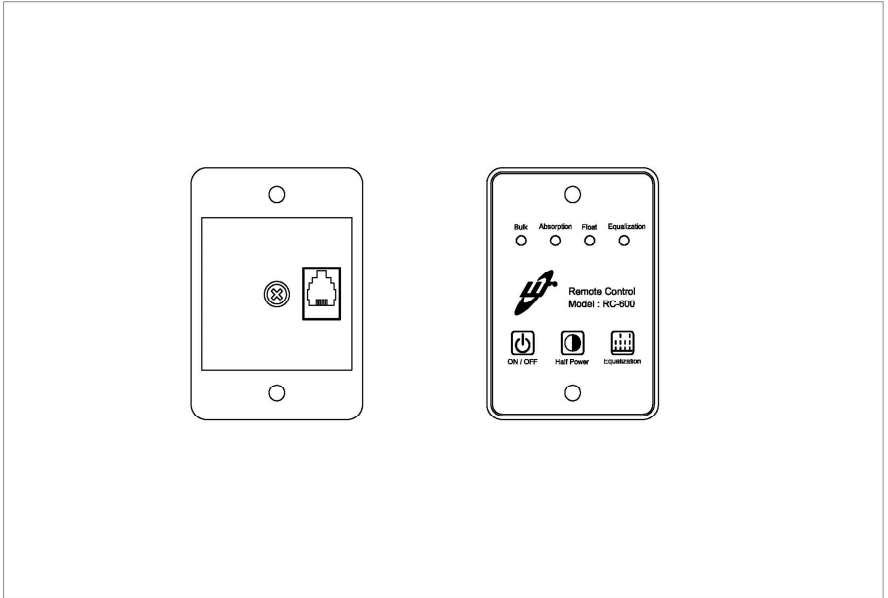

Figure 7 Remote Controller RC-600

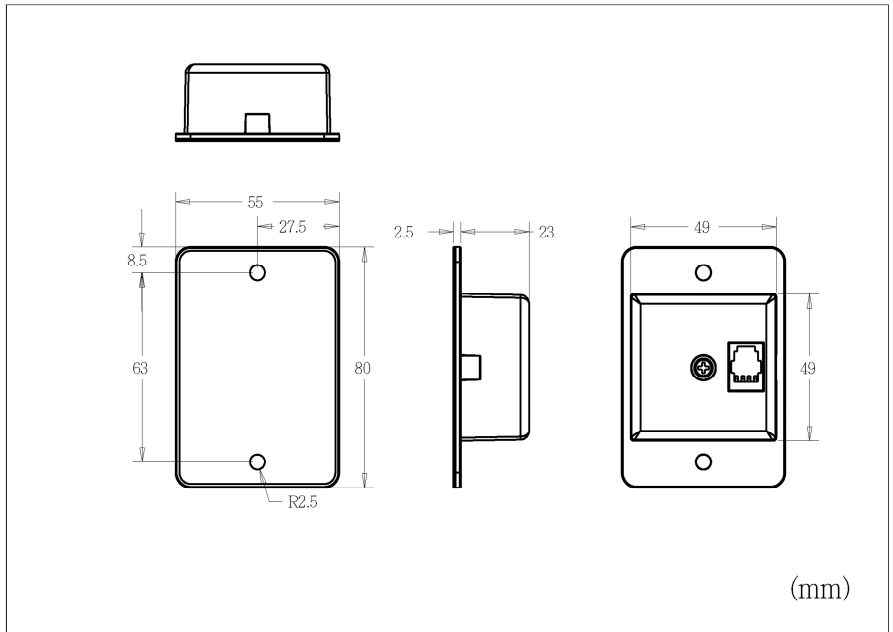

Figure 8 Remote Controller RC-600 Views

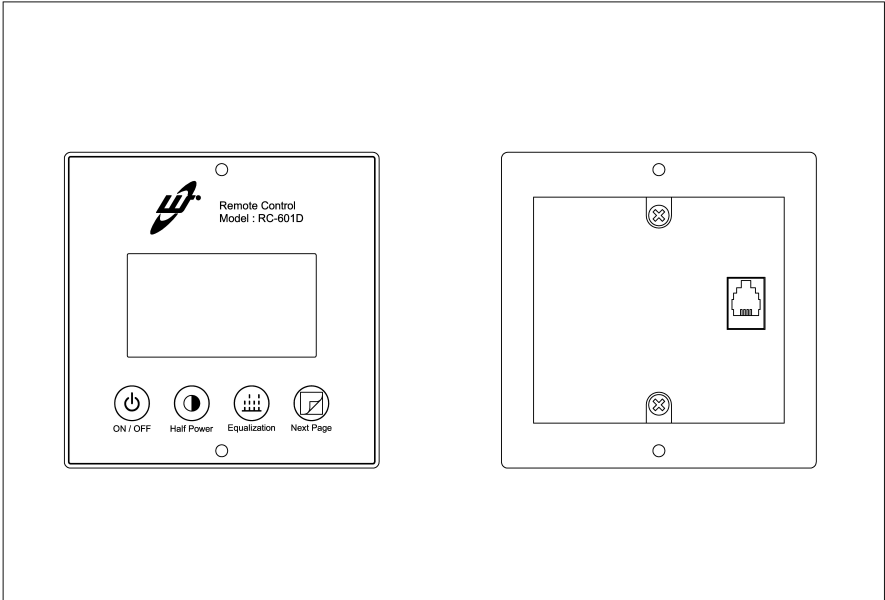

Figure 9 Remote Controller RC-601D

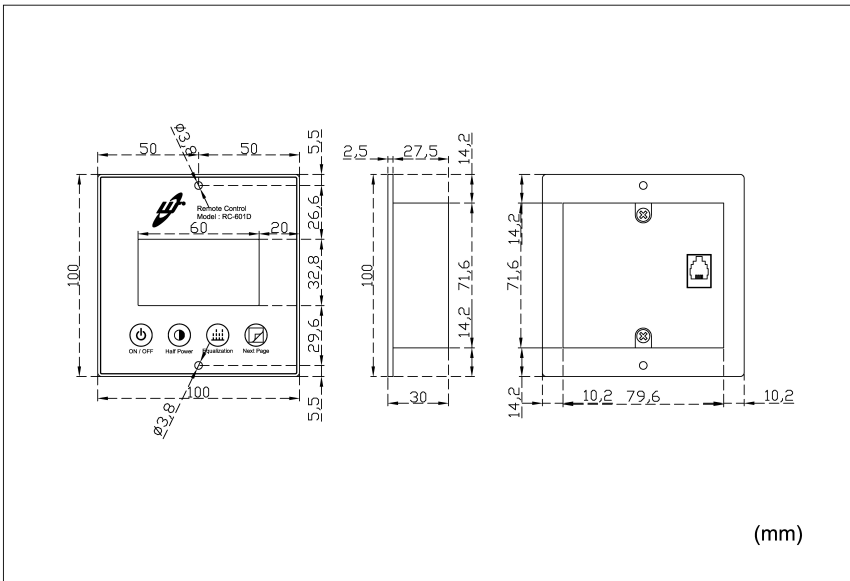

Figure 10 Remote Controller RC-601D Views

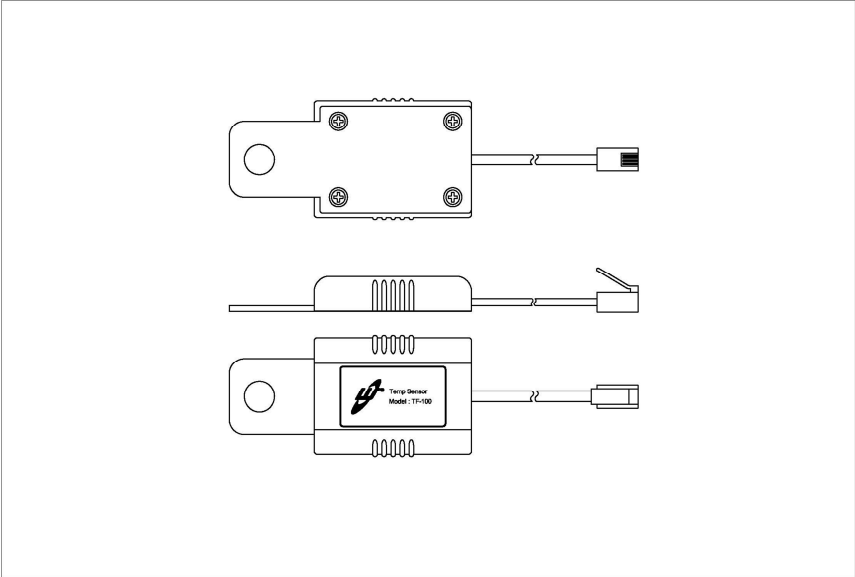

Figure 11 Temperature Sensor TF-100

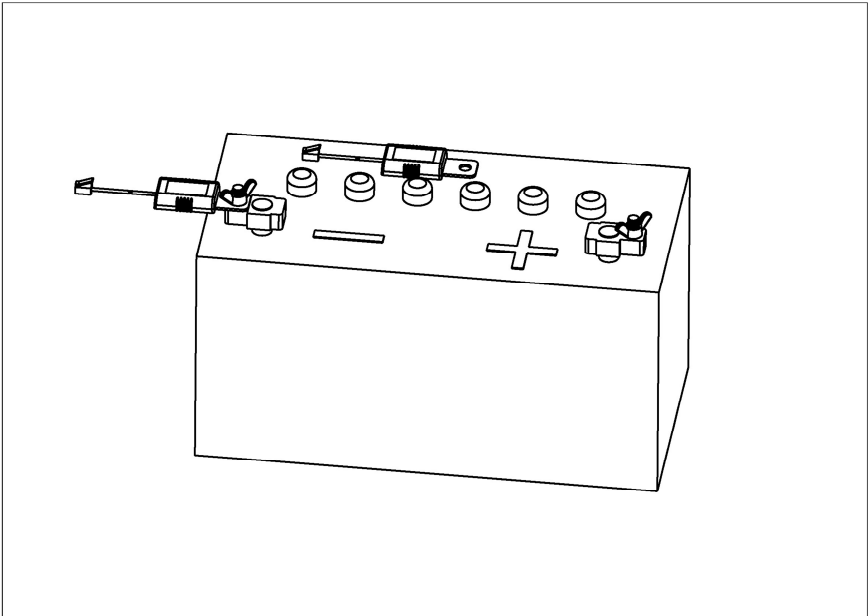

Figure 12 Temperature Sensor Setup

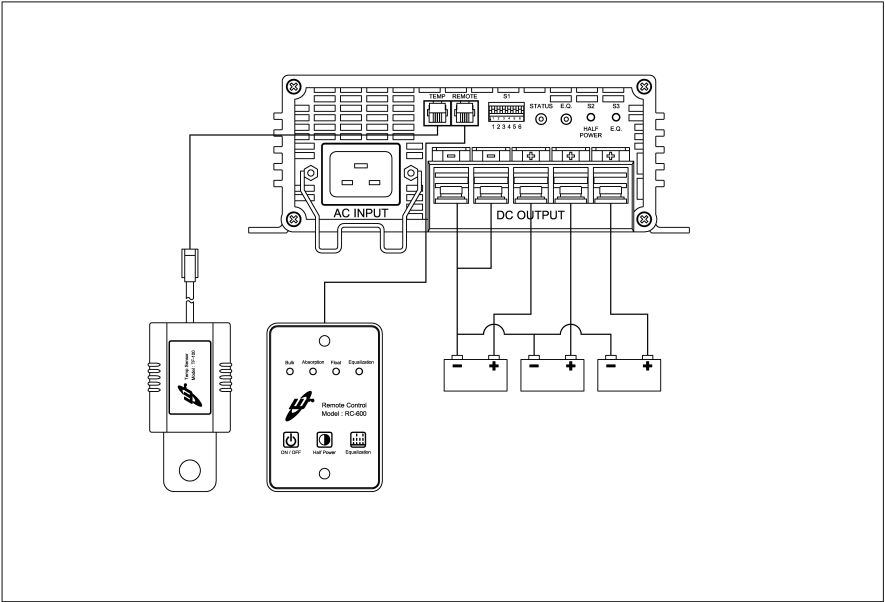

Figure 13 Making Connections (RC-600)

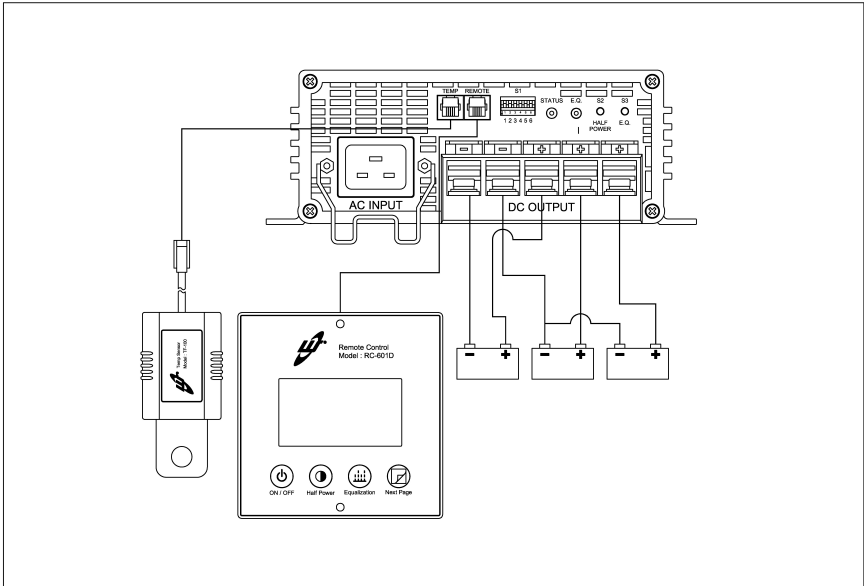

Figure 14 Making Connections (RC-601D)

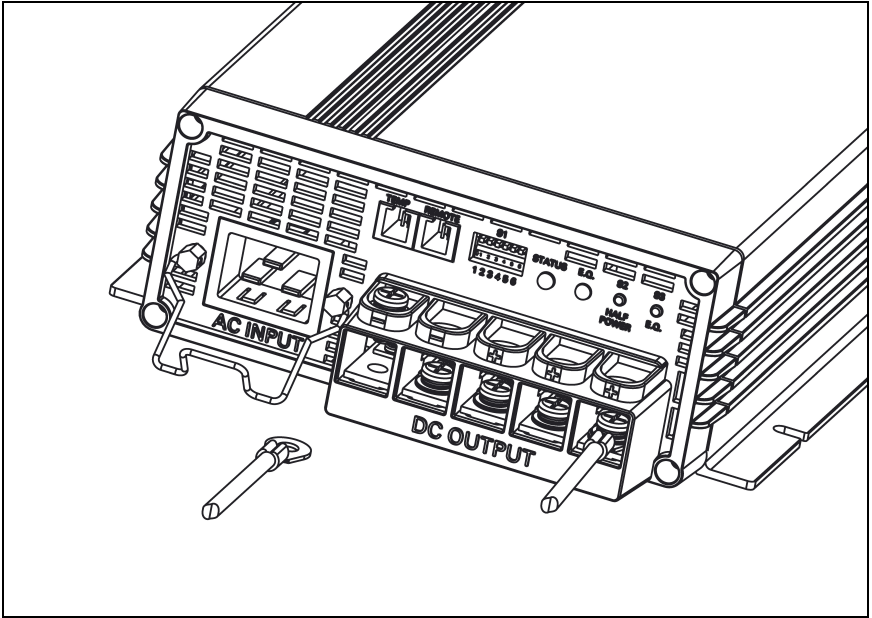

Figure 15 Cable Setup

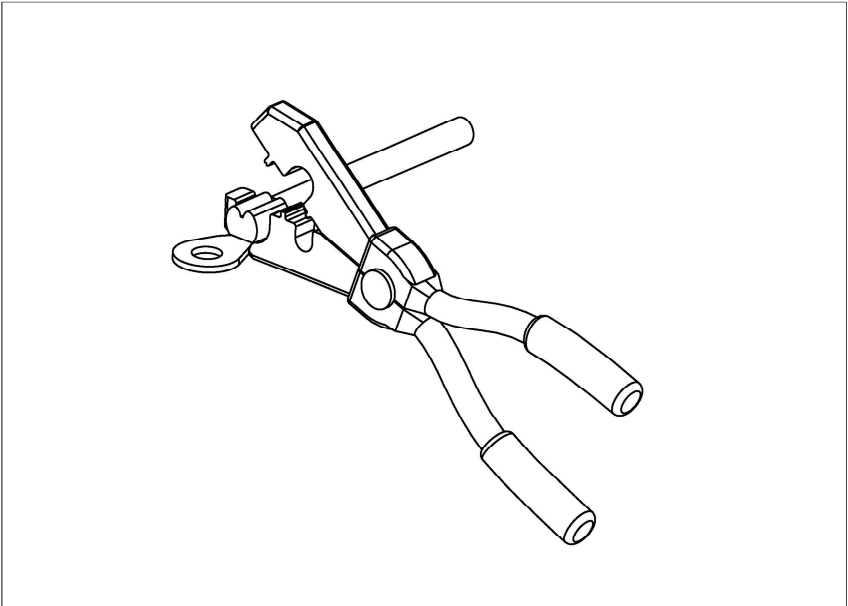

Figure 16 Fork

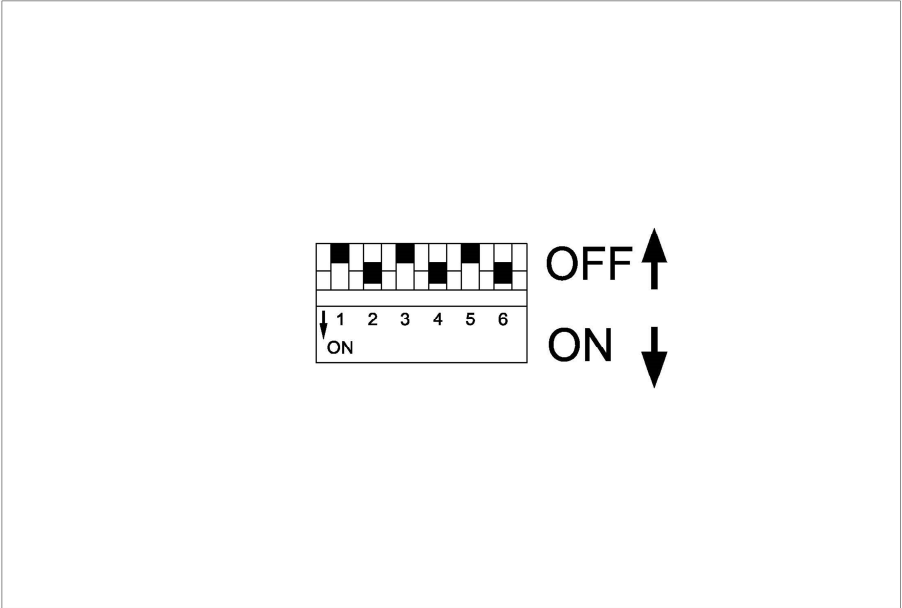

Figure 17 Switch

Contents

- 1 General safety and Installation instructions 14**
 - 1.1 Operating the device safely..... 14
 - 1.2 Safety instructions when installing the device..... 14
 - 1.3 Electrical cables 14
 - 1.4 Installation on boats 15
- 2 WARNING..... 15**
- 3 Applications and Descriptions 16**
- 4 Introduction of the unit variants..... 17**
- 5 Accessories 18**
 - 5.1 Temperature Sensor TF-100 18
 - 5.2 Remote controller RC-600 18
 - 5.3 Remote Controller RC-601D 19
- 6 Mounting of Battery Charger 20**
- 7 Making Connections 20**
- 8 Settings 21**
 - 8.1 Charging voltage setting 21
 - 8.2 Half power mode setting 22
 - 8.3 Equalization setting..... 22
 - 8.4 VOID setting table..... 22
- 9 Using the Charger 23**
 - 9.1 Charging characteristic 23
 - 9.2 Using the remote controller RC-600..... 25
 - 9.3 Units with Temperature Sensor TF-100 26
 - 9.4 Fan Speed..... 28
 - 9.5 Functional check 29
- 10 Trouble Shootings 30**
 - 10.1 The battery voltage would NOT increase after charging 30
 - 10.2 The battery is NOT fully charged after a charging time about 20 hours
30
 - 10.3 The battery discharges after a short period of time without usage.. 30
 - 10.4 Please refer to the following table for other trouble shootings..... 31
- 11 Specifications..... 32**

1 General safety and Installation instructions

1.1 Operating the device safely



Warning!

Failure to observe this instruction can cause material damage, device malfunction, or danger of bodily injuries.

Fundamental safety measures should be observed when using electrical equipment to avoid the danger of:

- **Electric shock**
- **Fire hazard**
- **Injury**

1.2 Safety instructions when installing the device

- Handle the batteries with care; they contain strong acids.
- Avoid contact with the battery fluid agent.
- If come in contact with battery fluid, one should rinse the affected parts of the body or clothing with plenty of cold water and seek medical attention immediately.
- Be sure that the device has a firm foundation.
- Do **NOT** use sharp or hard objects to clean the device; doing so may cause device damage.

1.3 Electrical cables

If cables have to be fed through metal walls or other walls with sharp edges, use ducts or wire bushings to prevent damage.

- Lay the cables so that other people will **NOT** trip over them.
- Do **NOT** lay cables which are loose or bent next to electrically conductive materials.
- Do **NOT** pull the cables.
- Fasten the cables properly.
- Lay the cables so that they cannot be easily damaged
- Always use sockets that are grounded and secured by earth leakage circuit breaker.
- Only a specialist should make the electrical connections.
- Do **NOT** lay the 115VAC / 230VAC line and the 12VDC / 24VDC in the **SAME** cable duct!
- Keep to the indicated minimum cable cross-section.

1.4 Installation on boats

- Incorrect use or installation of the charger on boat may lead to corrosion of the boat. Please allow qualified personnel to perform the installation of the charger.

2 WARNING



Warning!

Please read carefully about the following precautions.

Damages caused by failure to follow the instructions below will **NOT** be covered by warranty.

- Use the charge only as intended.
- Do **NOT** operate the charger if the housing or the cables are damaged.
- The charger may **NOT** be used to charge any other type of batteries than the ones indicated.
- Do **NOT** operate the device in a damp or wet environment.
- Do **NOT** charge a frozen battery; there is the danger of explosion.
- Keep this charger in a safe place, out of reach of children.
- Only qualified personnel who are familiar with the risks involved and the relevant regulations should carry out maintenance or repair work.
- The device must be fixed and installed in such a way that it will **NOT** fall over or fall down.

3 Applications and Descriptions

The chargers regenerate power or recharge mobile batteries used onboard vehicles or boats.

The charger can continuously charge supply batteries or starter batteries, enabling the batteries to maintain at a high capacity level.

The charger can be used for charging three types of batteries:

- Gel batteries
- Lead-acid starter batteries
- Maintenance-free batteries

Please inquire your battery supplier about the maximum capacities of your lead-acid batteries.

The charger is equipped with a polarity protection; this prevents the charger from being damaged in case of incorrect polarity.

An optional temperature sensor, (Figure 11 Temperature Sensor TF-100, Page. 9) that is connected at the battery being charged protects the battery against damage cause by varying outside temperature by adapting the charging voltage of the temperature to the battery. Please connect two ends of Figure 11 Temperature Sensor TF-100 on Page 9 – one end to “**TEMP**” socket on front panel and another end to the battery.

Optional remote controllers (Figure 7 Remote Controller RC-600, Page. 7 or Figure 9 Remote Controller RC-601D, Page. 8) can be obtained in order to provide remote access to the charger.

4 Introduction of the unit variants

The 4-stage battery charger can deliver different unit variants. It can charge batteries up to the specified battery capacity as indicated in the specification section. Regarding the identification of the specification of your unit, please see the model number on the type plate.

Front view Model-No.: WSC-1250, WSC-1280, WSC-2425, WSC-2440

(See Figure 1 Charger Front View, Page. 4)

The units can charge up to two supply batteries.

No. Description

1. "TEMP" connection for temperature sensor (accessory TF-100)
2. "REMOTE" connection for remote control (accessory RC-600)
3. Switch field S1 for the selection of the charging voltage, charging time limitation and power supply mode (see also Figure 17 Switch, Page. 12)
4. "STATUS" LED
5. "E.Q." equalization LED
6. On/Off switch S2 for half power mode
7. Switch S3 for equalization on only
8. "+" (plus) DC output terminal for the supply battery
9. "-" (minus) DC output terminal for the supply battery
10. Connection for AC input 100~240 volts voltage
11. Plug holder

Rear view

(See Figure 2 Charger Rear View, Page. 4)

No. Description

1. Ventilation outlet
2. Power switch

5 Accessories

5.1 Temperature Sensor TF-100

The temperature sensor (Figure 11 Temperature Sensor TF-100, Page. 9) measures the temperature of the battery or the environment around the battery and transfers the data to the charger. With deviating temperatures, the charging voltage increases and decreases accordingly.

5.1.1 Functions

- The temperature sensor transmits the battery temperature to the charger.
- The charging voltage is adjusted according to the temperature measured.

5.1.2 Installation

- Lay the cables from the batteries to the charger.
- Connect the temperature sensor to the "**TEMP**" socket of the charger.
- Connect the temperature sensor to the negative pole of the battery, or use a double-sided adhesive tape to attach the sensor to the top of the battery or in the vicinity of the battery (see Figure 12 Temperature Sensor Setup, Page. 9)

Note

The length of TF-100 cable is 5M.

5.2 Remote controller RC-600

Figure 7 Remote Controller RC-600, Page. 7.

5.2.1 Functions

- Switch the charger ON and OFF.
- Half power mode on/off.
- Equalization on

Note

Attach the remote control at a well accessible place to ensure easy access of the charger.

Caution!

Be careful when attaching the remote control, for wiring harnesses, cables and other components that are in the assembly range could be damaged in the process!

5.2.2 Installation

- Ensure approximately 49mm width, 49mm height and 23mm depth for the take-up of the remote controller (see Figure 7 Remote Controller RC-600,

Page. 7).

- Connect the remote control to the charger. The connection cable is equipped with two equivalent modular plugs.
- Place the remote control into the opening created. Secure the remote control with screws on the upper and bottom margin of the faceplate – use the available drills.

Note

The length of RC-600 cable is 10M.

Note

The power switch at the unit must be switched ON, so that the unit can be switched ON and OFF with the remote controller.

5.3 Remote Controller RC-601D

The remote controller RC-601D, (Figure 9 Remote Controller RC-601D, Page. 8) displays real-time information, settings and count down for different charging stages.

5.3.1 Functions

- Switch the charger ON and OFF.
- Half power mode ON / OFF.
- Equalization ON.
- Display real-time information and settings.

Note

The power switch at the charger must be switched ON, so that the charger can be switched ON and OFF by the RC-601D remote controller.

Caution!

Be careful when attaching the remote control, for wiring harnesses, cables and other components that are in the assembly range could be damaged in the process!

5.3.2 Installation

- Connect this remote controller to the “**REMOTE**” socket of the charger (Figure 14 Making Connections (RC-601D), Page. 10).
- Ensure approximately 79mm width, 71mm height and 28mm depth for the take-up of the remote controller.
- Connect the remote controller to the charger. The connection cable is equipped with two equivalent modular plugs.
- Place the remote controller into the opening created. Secure the remote controller with screws on the upper and bottom margin of the faceplate – use the available drills.

Note

The length of RC-601D cable is 10M

6 Mounting of Battery Charger

For mounting battery charger on wall or flat places (please refer from Figure 3 Charger Top View, Page. 5) regarding the size of housing and the location of mounting holes for your installation.

7 Making Connections

Refer to Figure 13 Making Connections (RC-600), Page. 10 or Figure 14 Making Connections (RC-601D), Page. 10.

- Place the charger in a dry, cool, clean, and ventilated space.
- Set the power switch to “0” (off) and pull out the main plug before connection or disconnecting the direct current connection.
- Connect the “-”(minus) battery pole with a connecting cable with the “-”(minus) terminal at the charger (see Figure 13 Making Connections (RC-600), Page. 10).
- Connect the “+”(plus) battery pole with the connecting cable with the “+”(plus) terminal at the charger (see Figure 13 Making Connections (RC-600), Page. 10).
- Lay the cables from the batteries to the charger.
- Fold the cable ends with the multicore cable ends.
- Supply the cable with a fork connection for an idea connection with the terminal (see Figure 16 Fork, Page. 11).

Ensure correct polarity of the battery and the battery charger, otherwise the internal flat-pin terminal will trigger with the wrong polarity.



Warning!

**Batteries with cell connection may NOT be charged.
Explosive gases could result from battery overheating.**

Note

Only use cables with the designated wire cross sections to connect the IUoU automatic charger to the battery.

Table 7-1 Battery Types

Model No.	Supply battery
WSC-1250	AWG # 4 ~ AWG # 6
WSC-1280	AWG # 2 ~ AWG # 4
WSC-2425	AWG # 8 ~ AWG # 10
WSC-2440	AWG # 4 ~ AWG # 6

8 Settings

8.1 Charging voltage setting

The switch field S1 can be used to select the charging voltage, equalization voltage, charging time and the operation mode of this charger (see Figure 17 Switch, Page. 12).



Warning!

Please follow the table below to ensure correct operation of the charger

Settings for the charging voltage for WSC-1250, WSC-1280 / WSC-2425, WSC-2440:

Table 8-1 Switch Configure Charging Voltage

Switch 1	Switch 2	I phase voltage	Uo phase voltage	U phase voltage
OFF	OFF	13.5V/27.0V	14.0V/28.0V	13.5V/27.0V
OFF	ON	13.5V/27.0V	14.4V/28.8V	13.5V/27.0V
ON	OFF	13.8V/27.6V	14.4V/28.8V	13.8V/27.6V
ON	ON	13.8V/27.6V	14.8V/29.6V	13.8V/27.6V

Table 8-2 Switch Configure Equalize Voltage

Switch 3	Equalization voltage
OFF	Same as Uo phase voltage
ON	15.5V/31.0V

Table 8-3 Switch Configure Power/Charger Mode

Switch 4	Operation mode
OFF	Battery charger
ON	Power supply 13.2V/26.4V

Table 8-4 Switch Configure Uo Phase Time Limit

Switch 5	Switch 6	Charging time
ON	OFF	4 hours
OFF	ON	6 hours
ON	ON	8 hours
OFF	OFF	Unlimited

8.2 Half power mode setting

When the switch S2 "HALF POWER" is pushed, the output power will reduce to half the chargers' amp rating and the "STATUS" LED will flash. The switch S2 is a kind of no memory switch. That means "ON/OFF" status cannot be identified from the switch. To enter and exit the "HALF POWER" mode by turns by pushing the switch S2. The "HALF POWER" mode can be told from flashing "STATUS" LED.

Due to the fan speed is adjusted according to the function of the load and the temperature inside the charger, when "HALF POWER" mode is on, the fan speed will be slowed down and become silent because of output current reducing to half the charger amp rating.

Note

1. The half power mode can be set only when equalization function is **NOT** activated or the charger is **NOT** in the power supply mode. (see Table 8-5 VOID Setting table for pushing switch on front panel, Page. 22)
2. Please refer to section 9.4 on page 28 to understand the function of fan speed.

8.3 Equalization setting

When the switch S3 "E.Q." is pushed, the function of equalization is activated and the "E.Q." LED will light RED. Whenever the function of equalization is activated, it only can be cancelled by turning off the charger.

Note

The equalization function can be set only when the charger is **NOT** in the half power mode and **NOT** in the power supply mode. (See Table 8-5 VOID Setting table for pushing switch on front panel, Page. 22)

8.4 VOID setting table

To avoid the void setting, please refer to Table 8-5 VOID Setting table for pushing switch on front panel, Page. 22.

Table 8-5 VOID Setting table for pushing switch on front panel

Push switch on front panel	Original working mode			
	Half power	Equalization	Others	Power Supply
S2 "HALF POWER" pushed	Exit "HALF POWER" ("STATUS" LED lights)	VOID	Enter "HALF POWER" ("STATUS" LED flashing)	VOID
S3 "E.Q." pushed	VOID	VOID	Equalization ("E.Q." LED lights Red)	VOID

9 Using the Charger

9.1 Charging characteristic

The charging characteristic is generally designated as a modified IUoU characteristic.

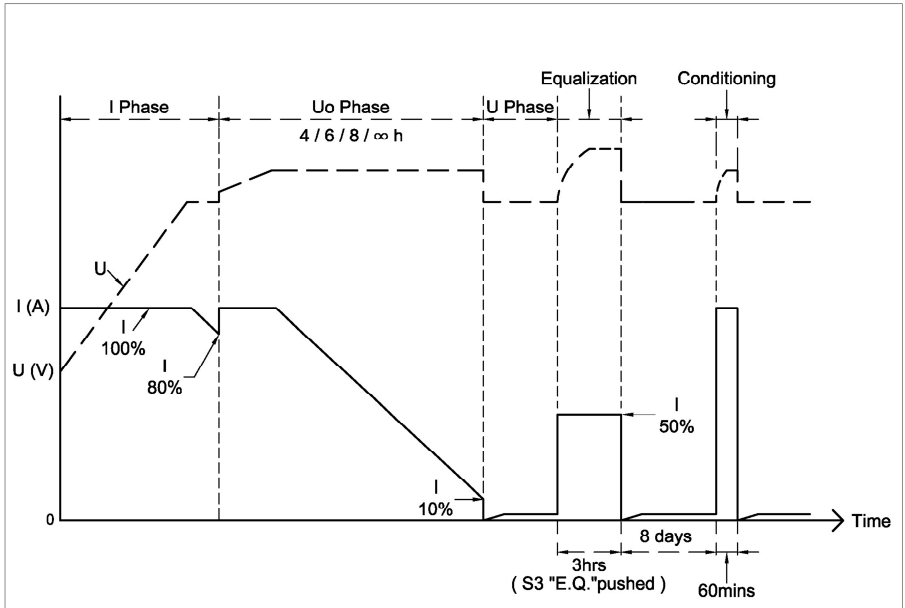

Figure 18 Charging characteristic

9.1.1 I phase (bulk)

The "STATUS" LED constantly lights Red.

In the first stage of the charging process, the depleted battery is charged with a constant current until the battery voltage reaches I phase setting voltage (13.5V/13.8 V or 27.0V/27.6 V). When the battery reaches this voltage level, the charging current gradually drops. When the current drops down to 80%, the charger switches over to Uo phase setting voltage (14.0V/28.0V or 14.4 V/14.8 V or 28.8 V/29.6 V). Typically the battery is charged to 70-80% of its capacity.

9.1.2 Uo phase (absorption)

The "STATUS" LED constantly lights Orange.

This main charging phase could be set to the maximum of 4/6/8 hours or unlimited, and the current rises again to its maximum value. The current remains constant as long as the battery voltage is below Uo phase setting voltage (14.0V/28.0V or 14.4 V/14.8 V or 28.8 V/29.6 V).

After reaching the setting voltage, it remains constant. However, the current drops again. Within this main charging phase, the battery is charged to 95% of its capacity.

Note The charging voltage and the period for the main charging phase (Uo phase) can be selected using the switch field S1.

9.1.3 U phase (float)

The "STATUS" LED constantly lights Green.

If the current decreases to 10% or under the rated current or if the time limit of 4/6/8 hours is exceeded, then the charger switches over to economy charging (13.5V/13.8 V or 27.0V/27.6 V).

Note

Batteries may be charged separately from each other if the chargers have double charging or three-fold charging connections. The outputs are separated internally by diodes, thus the weaker battery will be always first charged to the charging level of the stronger battery.



Attention

The maximum battery capacity should **NOT** exceed the specified capacity, otherwise the functions of the individual charging phases could be influenced.

9.1.4 8-day conditioning

If the battery charger stays at U phase for **8** days, it will switch back to 3-stage charging IUoU, and stay at Uo phase for **60** minutes to revive the battery.

Note

1. 8-day conditioning will be terminated whenever equalization function or half power mode is activated.
2. When the charger is in the equalization stage or half power mode, 8-day conditioning will **NOT** be triggered.

9.1.5 Equalization

The function of equalization could be activated as long as the battery charger is **NOT** in the half power mode or power supply mode.

The function of equalization will be activated only when the battery is charged and stays in Uo phase with < 25% of Full load current.

The battery charger will charge the battery 3 hours with equalization setting voltage (15.5V or Uo phase setting voltage) and half of rated current.

Note

Once the equalization function is activated, it can only be cancelled by turning off the battery charger.

9.2 Using the remote controller RC-600

There are three buttons and four LEDs on RC-600 (see Figure 7 Remote Controller RC-600, Page. 7).

- ON/OFF button to switch the charger ON and OFF
- Half Power button to enter/exit "HALF POWER" mode
- Equalization button to activate the function of equalization
- Bulk LED to indicate the charging stage of I phase
- Absorption LED to indicate the charging stage of U_o phase
- Floating LED to indicate the charging stage of U phase
- Equalization LED to indicate the function of equalization is activated

To avoid the **VOID** setting from the remote control, please refer to Table 9-1 VOID Setting.

Table 9-1 VOID Setting table for pressing button on remote controller

RC-600 buttons	Charger working mode			
	Half power	Equalization	Others	Power Supply
"HALF POWER" pressed	Exit "HALF POWER" ("STATUS" LED lights)	VOID	Enter "HALF POWER" ("STATUS" LED flashing)	VOID
"Equalization" pressed	VOID	VOID	Equalization ("E.Q." LED lights Red)	VOID
"ON/OFF" pressed	Stand by ("STATUS" LED slowly flashing Red)	Stand by ("STATUS" LED slowly flashing Red)	Stand by ("STATUS" LED slowly flashing Red)	Stand by ("STATUS" LED slowly flashing Red)

Note

- The power switch at the unit must be switched ON, so that the unit can be switched ON and OFF with the remote control.
- The "ON/OFF" button on the RC-600 should be pressed for 2 seconds to switch OFF the battery charger, and 0.5 second to turn ON.

9.3 Units with Temperature Sensor TF-100

A temperature sensor (Figure 11 Temperature Sensor TF-100, Page. 9) can be connected in order to provide the optimum charging functioning. The charging voltages, as can be seen from the following diagrams, vary, depending on the battery temperature.

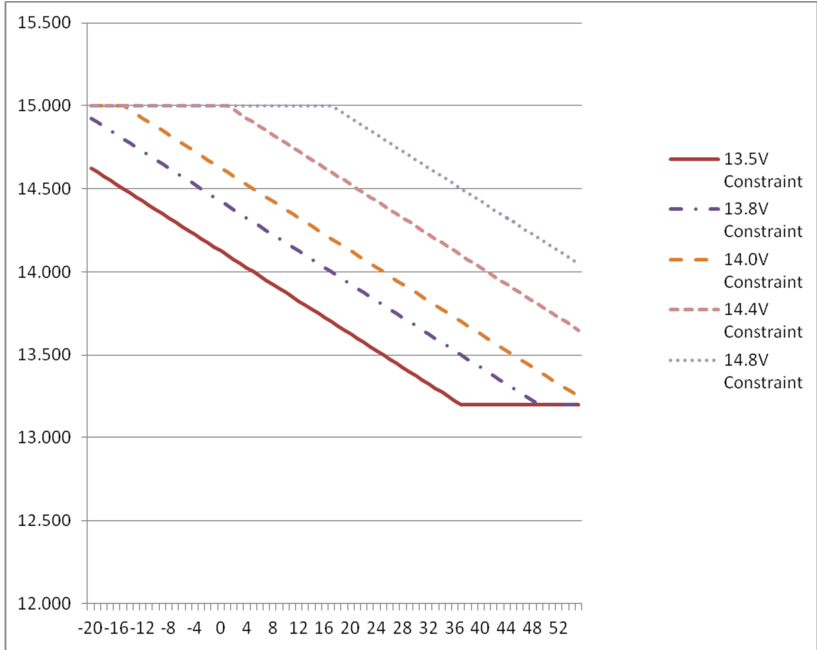

Figure 19 Temperature Compensation for 12V Model

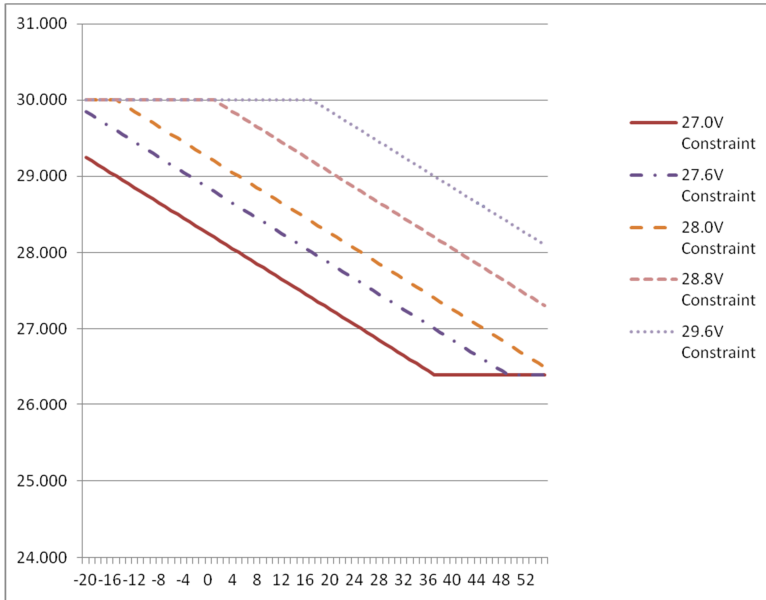

Figure 20 Temperature Compensation for 24V Model

Note

- The temperature sensor is only working in I, Uo and U phases.
- The output voltage is adjusted according to the function $-25\text{mV}/^\circ\text{C}$ for WSC-1250, WSC-1280 / $-50\text{mV}/^\circ\text{C}$ for WSC-2425, WSC-2440. However, the maximum output voltage is 15V / 30V, and the minimum is 13.2V / 26.4V.
- When the battery temperature detected via TF-100 reaches 55°C , the charger will stop the charging process ("E.Q." LED flashing Red and "STATUS" LED lights Orange), and auto recover when temperature drops to 45°C .

9.4 Fan Speed

The fan speed is adjusted according to the function of the load and the temperature inside the charger.

When the load is over 70% of the chargers' amp rating, the fan will turn in 100% speed.

If the load is below 70% of the chargers' amp rating, the fan speed will be determined according to the temperature inside the charger.

When the temperature goes up, the fan will start turning with temperature 45°C, and reach 100% speed with temperature 65°C.

When the temperature goes down, the fan will slow down the turning speed with temperature 60°C, and stop turning with temperature 40°C.

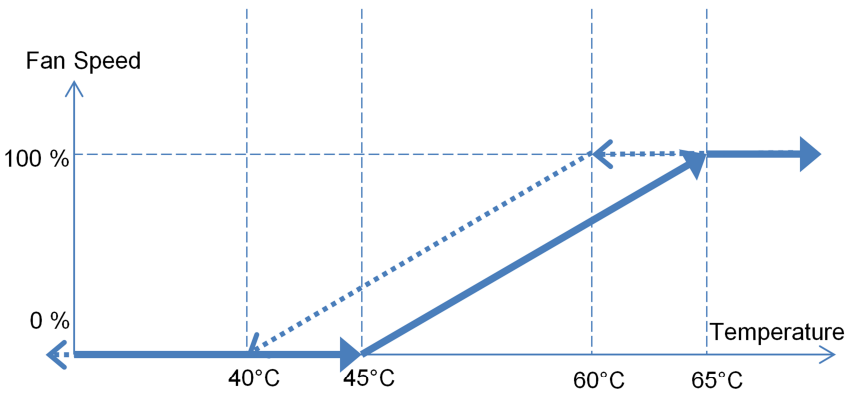

Figure 21 Fan Speed

9.5 Functional check

9.5.1 Charging phases

The status LED in the front of the unit can be used to check the status of the charging process.

Note

The optional remote control can also be used to check the status of the charging process. The LEDs on the remote control indicate the different charging phases with its respective colors.

Table 9-2 Normal Functional Check Table

"E.Q." LED	"STATUS" LED	Status
	Red, constantly lit	I phase
	Orange, constantly lit	Uo phase
	Green, constantly lit	U phase
Red, constantly lit	Red, constantly lit	I phase, Equalization is activated
Red, constantly lit	Orange, constantly lit	Uo phase, Equalization is activated
Red, constantly lit	Green, constantly lit	U phase, Equalization is activated
Red, constantly lit		Equalization is executed
	Red, flashing	I phase, half power
	Orange, flashing	Uo phase, half power
	Green, flashing	U phase, half power
	Green, double flashing	Power supply mode
	Red, slowly flashing	Stand-by mode (RC-600)

10 Trouble Shootings

10.1 The battery voltage would NOT increase after charging

- If possible, measure with a suitable multi-meter during the charging to verify if the voltage at the battery terminals increases.
- Determine whether the terminals are connected properly to the battery poles. Clean the battery poles if necessary to ensure better connection.

10.2 The battery is NOT fully charged after a charging time about 20 hours

- Disconnect the power to the charger.
- Remove the battery from the charging terminals and wait for a few minutes.

Then, measure the voltage at the battery terminals with the multi-meter.

10.2.1 12 V battery

If the multi-meter displays a voltage of 10 V or less, this indicates that the battery is defective and cannot be charged any longer.

10.2.2 24 V battery

If the multi-meter indicates a voltage of 20 V or below, allow the battery be checked by a specialist, if necessary. Otherwise, dispose of the battery.

10.3 The battery discharges after a short period of time without usage.

Measure the voltage at the battery terminals with a suitable multi-meter. If the multi-meter indicates a voltage below 12 V of a 12 V battery or a voltage below 24 V of a 24 V battery, then the battery is too weak to retain the charge.

10.4 Please refer to the following table for other trouble shootings.

Table 10-1 Abnormal Functional Check Table

"E.Q." LED	"STATUS" LED	Status
Red, flashing	Red, constantly lit	Short circuit and low voltage, shut down
Red, flashing	Orange, constantly lit	Battery temperature abnormal, stop charging (TF-100)
Red, flashing	Red, flashing	Fan abnormal
Red, flashing	Orange, flashing	TF-100 connected to the remote socket
Red, flashing	Green, flashing	Charger overheated (>100°C), stop charging
Red, flashing	Red and green by turns	Charging voltage too high and shut down
Red, flashing	Orange and green by turns	Charging current too high and shut down
Red, flashing	Red and orange by turns	Defective fuse or reverse-polarity
Red, flashing for 10 seconds		Void setting

11 Specifications

Model Number	WSC-1250	WSC-1280	WSC-2425	WSC-2440
Input voltage range	100V AC ~ 240V AC			
Input frequency	50Hz ~ 60Hz			
Power factor correction	>0.97			
Efficiency at 230V AC	>91%	>92%	>93%	>93%
Efficiency at 115V AC	>89%	>90%	>91%	>91%
Input Current at 230V AC	3.62A	5.81A	3.51A	5.62A
Input Current at 115V AC	7.32A	11.67A	7.1A	11.33A
Charge mode	Normal 3-Stage / Equalization 4-Stage			
Output charging voltage	14V / 14.4V / 14.8V		28V / 28.8V / 29.6V	
Output float voltage	13.5V / 13.8V		27 / 27.6V	
Output power mode voltage	13.2V		26.4V	
Output charging current	0A ~ 50A	0A ~ 80A	0A ~ 25A	0A ~ 40A
Equalization mode	14.8V / 15.5V (0A ~ 25A)	14.8V / 15.5V (0A ~ 40A)	29.6V / 31V (0A ~ 12.5A)	29.6V / 31V (0A ~ 20A)
Half power mode (Silent mode)	0A ~ 25A	0A ~ 40A	0A ~ 12.5A	0A ~ 20A
Battery connection	3			
Battery types	Lead-acid/GEL/AGM/Li-Ion			
Battery capacity	500Ah	800Ah	250Ah	400Ah
Operating temperature	-20°C ~ +50°C			
Storage temperature	-40°C ~ +85°C			
Air humidity	10% ~ 90%			
Remote control (accessory)	RC-600 / RC-601D			
Temperature compensation (accessory)	TF-100			
Dimensions L*W*H (mm)	292*210*75	327*210*75	292*210*75	327*210*75
Weight	2.5Kgs	3Kgs	2.5Kgs	3Kgs

WSC Series 4-stage Battery Charger

Safety Standard:	EN 60335-1
	EN 60335-2-29
EMC Standard:	EMI: EN 55014-1
	EN 61000-3-2
	EN 61000-3-3
	EMS: EN 55014-2
	EN 61000-4-2,3,4,5,6,11
Protective devices:	Short circuit protection
	Over voltage protection
	Over current protection
	Battery charger over temperature
	Battery over temperature

The following accessories are available for our 4-stage battery charger:

Remote controller (Model number: RC-600)

Remote controller (Model number: RC-601D)

Temperature sensor (Model number: TF-100)

Certificates applied to the 4-stage battery charger:

